

BANTAM[®]

HIGH PERFORMANCE MANUALLY-OPERATED DOOR

The Economical, Break-Away Dock Door Alternative

The Bantam roll door is an economical fabric door alternative to high maintenance overhead dock doors. With the same crisp lines and fabric selection as our popular PredaDoor[®], it accommodates most dock applications. The Bantam door is ideal for interior or exterior openings with low to moderate traffic.

With manual operation standard via a pull-chain hoist, the Bantam can also be motorized for more convenient, and more automatic, opening and closing speeds, if desired.

Takes a Hit - Quick-Set[™], Break-Away[™] tabs allow bottom bar to be reset in just seconds, without tools, virtually eliminating downtime and repair costs.

Simple Operation - Chain hoist and speed governor make for easy manual door operation.

Minimal Space - Only 6-1/4 inches of side clearance and 3-3/4 inches of side column projection required.

Wind Resistance - Integral panel connecting ribs allows quick, inexpensive replacement of all panel sections and provides resistance to wind and negative pressure.

Visibility - 17 inch by 17 inch replaceable window is standard. Optional full-width vision panel is available.



BANTAM®

HIGH PERFORMANCE MANUALLY-OPERATED DOOR

Model Name

- Rytec® Bantam® Door

Size and Dimensions

- Up to 10' W x 10' H
- 20" headroom above lintel
- 8" side clearance, non-drive
- Left or right hand motor mount
- 4" side column projection
- 14.5" head projection
- 13" side clearance, drive side

Available Options

- Full width vision panel
- Hood, flat or slant
- 2-ply, USDA compliant or screen material
- Powered drive system complete with one open/close/stop push button and pneumatic reversing edge.
- 17" x 17" windows

Warranty

- One-year limited warranty on materials and workmanship.
- Three-year limited warranty on 2-ply™ panel material.

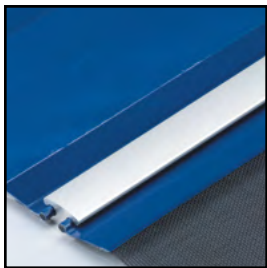

Integral wind rib with optional screen material

Door Panel

- Vinyl panel material with integral connective ribs allow for easy replacement of individual panels.
- Integral connecting ribs provide stiff resistance against wind and negative pressure.
- Velcro-sealed PVC or screen windows can be replaced quickly and easily

Break-Away™ Bottom Bar

- The Quick-Set Break-Away™ tabs permit the wireless bottom bar to release in either direction without damage to the door.
- Bottom bar can be reset in just seconds, without tools.



Easily resets, without the need for tools

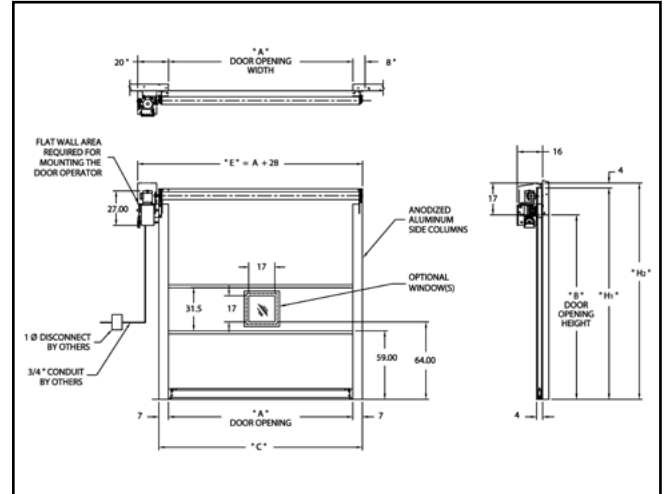

Manual Drive System

- Opening and closing is manually operated by use of chain hoist and speed governor.

Side Frames

- Fully bolt together anodized aluminum construction.
- Full height weatherseal to seal against panel material.



Manual Chain Hoist



888-GO-RYTEC RytecDoors.com
Tel 262-677-9046 Fax 262-677-2058
One Cedar Parkway Jackson, WI 53037-0403