

SPIRAL[®] LH[®]-HZ[®]

HIGH PERFORMANCE LOW HEADROOM HURRICANE ZONE DOOR

Low Headroom and High Security Join Forces Against Hurricanes

The Spiral Low Headroom Hurricane Zone Door brings high speed and high security to applications with unique space limitations in high velocity hurricane zones. Whether headroom is severely limited because of low ceilings, joists or other overhead obstructions, the LH-HZ is engineered for all types of low lintel challenges.

Clean lines and a refined structural design give the Spiral LH-HZ door a stylish and high-tech look. The anodized aluminum slats will not corrode, so you can count on that look to last for many years even under the worst weather conditions, including hurricanes.

Miami-Dade NOA - Certified independent testing and Notice of Acceptance (NOA) from Miami-Dade County Building Code Compliance Office - approved for use in High Velocity Hurricane Zones (HVHZ).

Low Headroom - The low lintel design requires only 11 inches of clearance.

High Security - Rigid, aluminum slat construction and optional integrated locking system provide unparalleled security.

Fast and Smooth - Opens effortlessly at up to 60 inches per second for improved traffic flow and greater access control. Counterbalance incorporates custom-engineered springs without bungee cords.

Lower Energy Costs - The fast opening and closing speeds minimize the air exchanged between climate controlled environments. A durable rubber membrane covers the reinforced hinges providing a tight seal.

Quiet Operation - The high performance technology and low headroom angled track offer a quiet and unobtrusive operation.

Total Digital Control - The highly advanced System 4[®] door controller enables precise door positioning, infinite speed adjustments and total control of all door functions.



SPIRAL[®] LH[®]-HZ[®]

HIGH PERFORMANCE LOW HEADROOM HURRICANE ZONE DOOR

Model Name

- Rytec[®] Spiral[®] LH[®]-HZ[®] Door

Certification

- Spiral SSN-HZ
Miami-Dade, Florida NOA No. 15-1014.04, 11/8/2017
Florida Building Code: FL# FL16612

Size and Dimensions

- Up to 16' W x 16' H
- Multiple door configurations based on door size.

Safety

- Thru-beam photo eyes
- Control-reliable electronic reversing edge

Warranty

- Five-year limited warranty on mechanical components.
- Two-year limited warranty on electrical components.

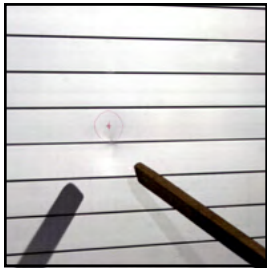
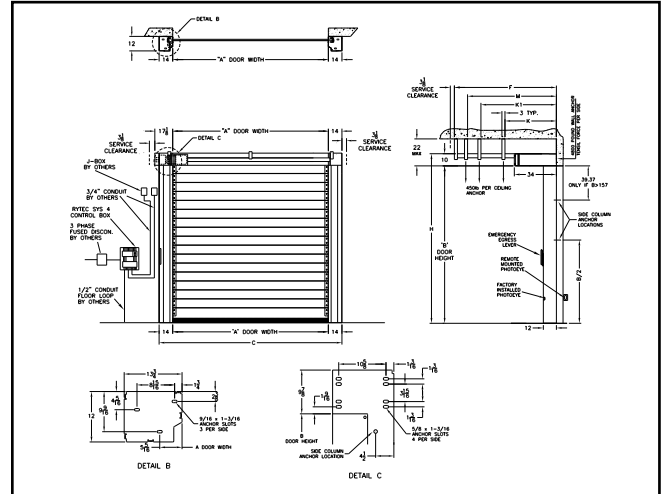

Heavy-duty panel built to withstand missile impacts in high velocity wind zones.

Hurricane Tested

- Rytec hurricane doors are independently tested and certified to withstand missile impacts in high velocity wind zones.
- Certified to withstand hurricane force winds of up to 175 mph.

Unique Track Design

- Special track design allows you to fit the low headroom door in areas with as little as 11 inches of clearance above door opening.
- Compact, variable speed motor with soft acceleration and deceleration and braking for smooth starts and stops.

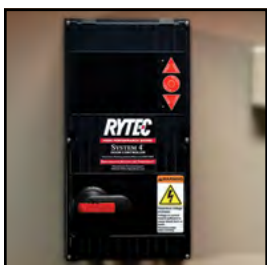

System 4 shown with optional rotary disconnect

Electrical Controls

- System 4[®] controller housed in a NEMA 4X rated enclosure with factory set parameters.
- Intelligent processor monitors and controls power consumption.
- Advanced self-diagnostics for troubleshooting.

Panel Design

- Integral rubber weatherseal between the slats provides a tight weatherseal across the entire panel.
- Rubber weatherseal is replaceable for easy maintenance.
- Patented hinge design allows for removal and replacement of single slat without disassembling the door panel.



Integral rubber weatherseal

Counterbalance System

- Up to six extension springs in each side column, depending on the size of the door.
- The springs assist the motor in opening, reducing motor wear and increasing the longevity of mechanical components.
- Mechanical egress lever on the side column allows the door to be opened in the event of a power failure.

Travel Speed

- Opens at up to 60 inches per second.



888-GO-RYTEC
Tel 262-677-9046
One Cedar Parkway Jackson, WI 53037-0403

RytecDoors.com
Fax 262-677-2058