

TURBO-SEAL® FREEZER

HIGH PERFORMANCE ROLLING DOOR

The Ultimate High-Speed Rolling Door for Freezers and Coolers.

The Turbo-Seal Freezer door is one of the fastest roll doors in the world. In a fast-moving cold storage environment, that translates into minimized air infiltration and improved traffic flow for superior productivity.

Designed to meet the needs of cold storage facilities, the Turbo-Seal's low profile design permits it to fit almost anywhere. Its tight seal conserves energy and the heated side columns and three defrost options virtually eliminate frost build up. Combine this with its ability to withstand the impact of a forklift, and the Turbo-Seal is the best high-speed freezer roll door on the market.



Fast - Opens at up to 100 inches per second. Conserves energy and maintains constant climate control.

Energy Efficient - Full-height dual vinyl weather-seals in side column. Low temperature vinyl seals in head and bottom bar.

Safe - Dual electric photo eyes and pneumatic dual-chamber reversing edge in bottom bar are standard.

Takes a Hit - Quick-Set™, Break-Away™ tabs allow bottom bar to be reset in just seconds, without tools, virtually eliminating downtime.

Frost Free - Three different defrost system options and heated side columns prevent frost build-up.

Low Profile - Side columns are only 8 inches wide with 6 inches of projection. Fits virtually anywhere.



TURBO-SEAL[®] FREEZER

HIGH PERFORMANCE ROLLING DOOR

Model Name

- Rytec[®] Turbo-Seal[®] Freezer Door

Size and Dimensions

- Up to 12' W x 16' H
- 23" headroom above lintel
- 7" side column projection
- 8" side column width
- 10.5" side clearances
- Head projection between 30.5" and 44"
- Motor on left, junction box for wiring in middle

Available Options

- Wind ribs
- Self-Repair side frame configuration

Warranty

- One year limited warranty on materials and workmanship.
- Three-year limited warranty on 2-ply Rilon[™] panel material.
- Lifetime warranty on counterweights.

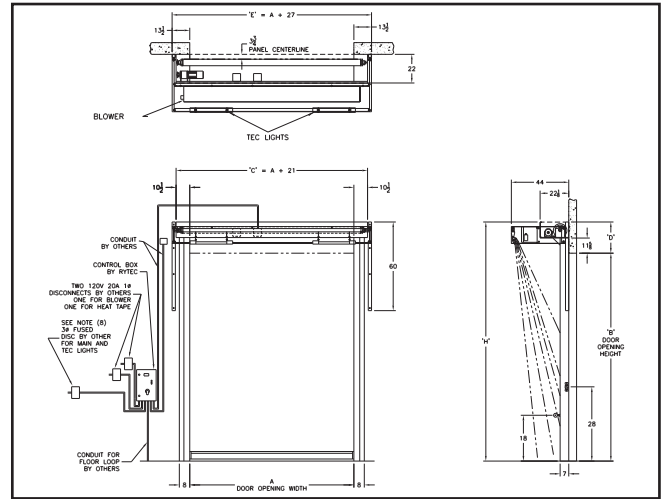

Break-Away tabs are easily reinserted into the side columns

Easy Reset

- Quick-Set, Break-Away tabs allow bottom bar to be reset in just seconds, without tools, after taking a hit.
- Cut off switch between tabs deactivates motor when door is hit.



Counterweights within side column assist the motor in opening and closing the door

Counterbalance System

- Guided counterweight design eliminates stress and strain on the motor.
- Counterweights allow for the use of a smaller motor, resulting in increased energy savings.

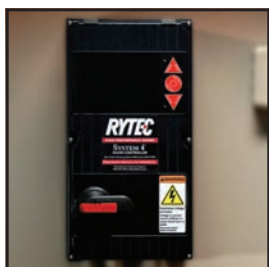

System 4 shown with optional rotary disconnect

Electrical Controls

- System 4[™] controller housed in a NEMA 4X rated enclosure with factory set parameters.
- Intelligent processor monitors and controls power consumption.
- Advanced self-diagnostics for troubleshooting.

Defrost System

- Three optional defrost systems are available to prevent frost build-up on the door panel.
- Options include Tec-Light[™] system, Tec-Lights with unheated blower and modulating heated blower system.



Tec-Lights with Unheated Blowers configuration



Pathwatch Safety Light System indicates door closing Turbo-Seal Insulated pictured above

Safety

- Standard dual thru-beam photo eyes.
- Standard sensitivity-adjustable pneumatic reversing edge.
- Standard Ry-Wi[™] Wireless System
- Standard Pathwatch[™] threshold warning lights



888-GO-RYTEC RytecDoors.com
Tel 262-677-9046 Fax 262-677-2058
One Cedar Parkway Jackson, WI 53037-0403