

P90 SPECIFICATION SHEET (WITH FOAM HEAD PAD)

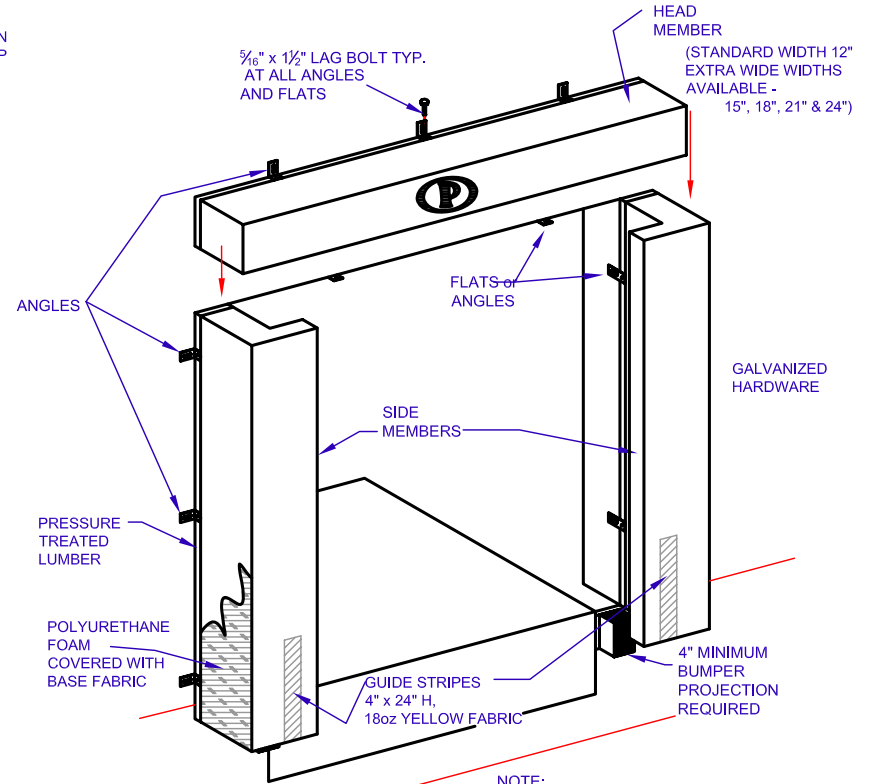
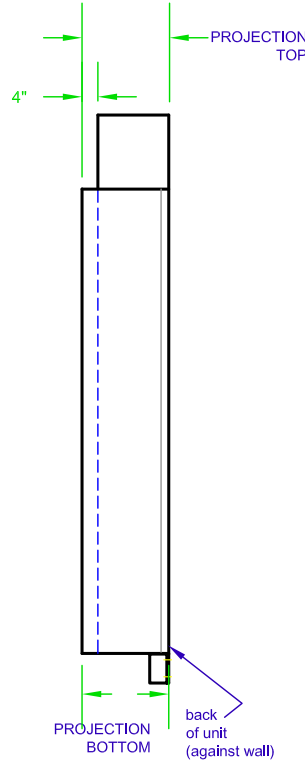
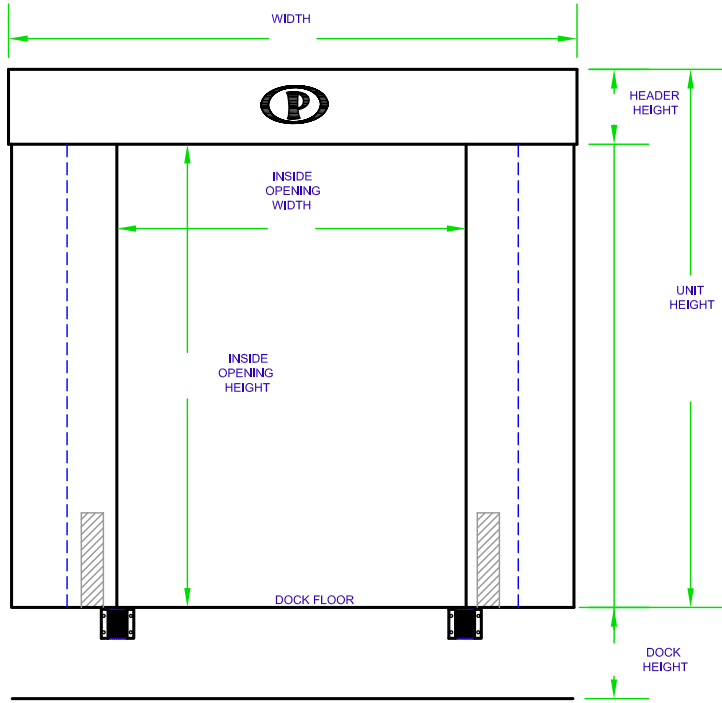

NOTE:
LOCATION OF ANGLES
& FLATS DETERMINED
BY INSTALLER TO SUIT
WALL CONFIGURATIONS.

SIDE PAD MOUNTING VARIATIONS: CIRCLE ONE

Enter Side Pad
Face Width:

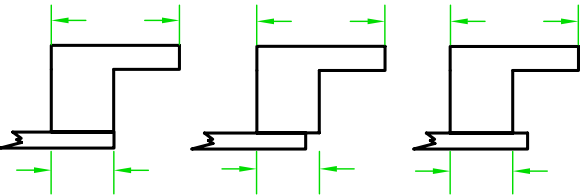

Enter Side Pad
Base Width:

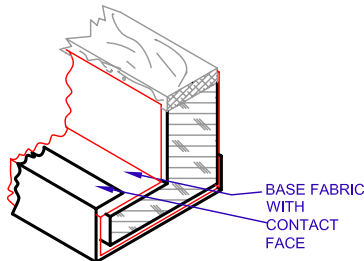
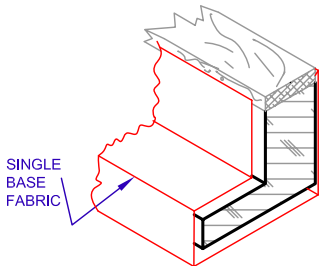

QUANTITY: _____, MODEL: _____
 UNIT SIZE: _____ WIDTH, _____ HEIGHT
 HEAD CURTAIN: _____ WIDTH, _____ DROP
 INSIDE OPENING WIDTH: _____
 INSIDE OPENING HEIGHT: _____
 PROJECTION: _____ TOP, _____ BOTTOM
 SIDE PAD: _____ HEIGHT, _____ WEDGE
 CHAIN FLAP: _____ WIDTH, _____ LENGTH
 BASE FABRIC: _____, COLOR: _____
 FACE FABRIC: _____, COLOR: _____

DOOR SIZE: _____ WIDTH, _____ HEIGHT
 DOCK HEIGHT: _____, BUMPER PROJECTION: _____

APPROACH: LEVEL DECLINE INCLINE
 _____" DIFFERENCE IN 50'-0"

OPTIONS:
 VELCRO SLIT: _____ HEIGHT.
 3 ROPE PULL-UP
 UNIT SUPPORT FRAME: WOOD STEEL
 INSIDE WRAP -
 MATERIAL: _____, HEIGHT: _____

SPECIAL INFORMATION



PERMA TECH, INC.

363 HAMBURG STREET • BUFFALO, NY 14204
 (716) 854-0707 • 1-800-DOC-SEAL
www.permatechinc.com

JOB: _____

DEALER: _____

CONTACT: _____

QUOTE #: _____

APPROVED BY SIGNATURE: _____